

Quartiererschliessung Pussanal-Zwy

Ausführungsprojekt

Querlprofile 1:100, Pussanalstrasse Los 3

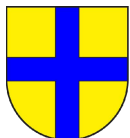

Gemeinde Grösch, Kanton Graubünden

Donatsch + Partner AG
Prättigauerstrasse 34 | CH-7302 Landquart
+41 81 307 89 00 | landquart@donatsch.ch

Plan Nr.: 103202.308		Format: 17xA4		
Projektleiter: MaMa				
Index	Änderung	Gez.	Freigabe	Datum
Genehmigung		NiSt	MaMa	28.06.2024
A				
B				
C				

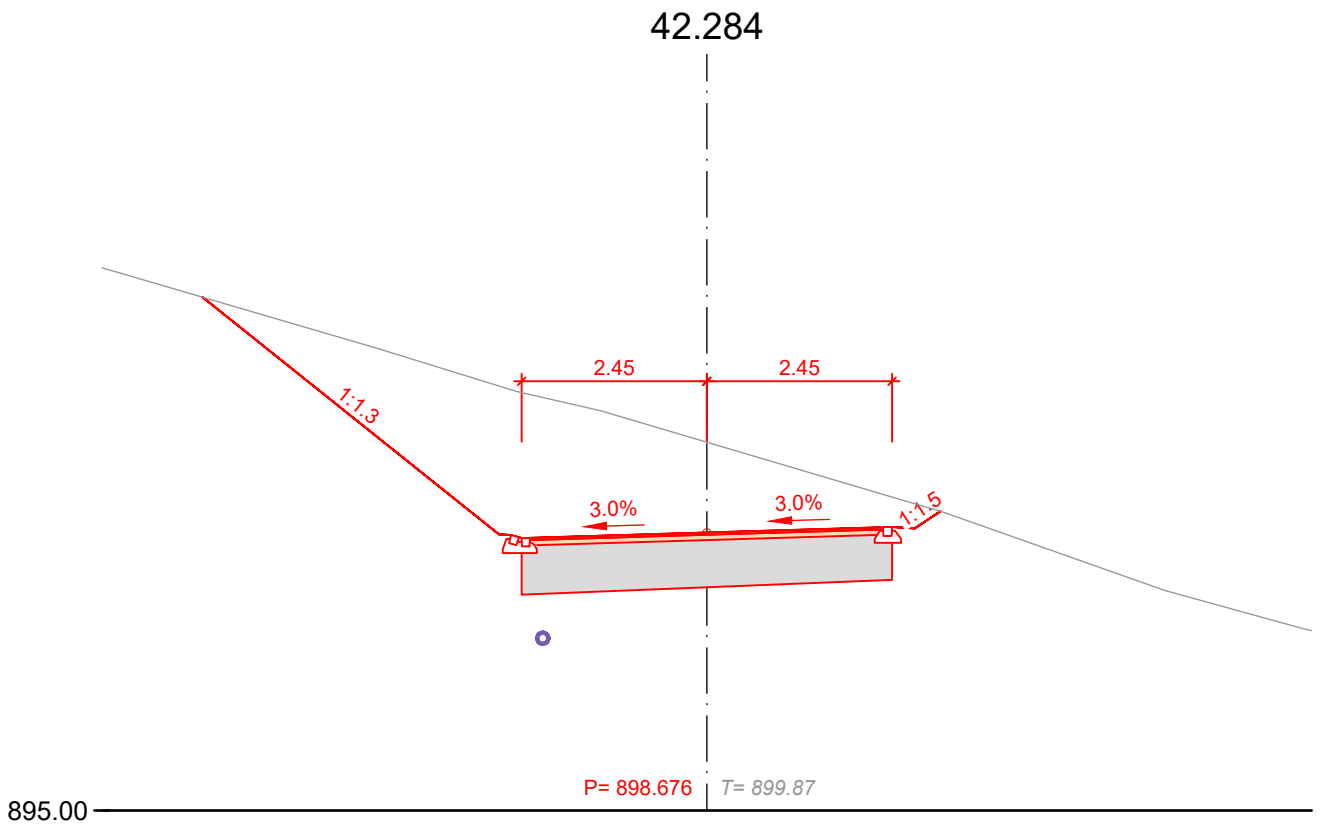
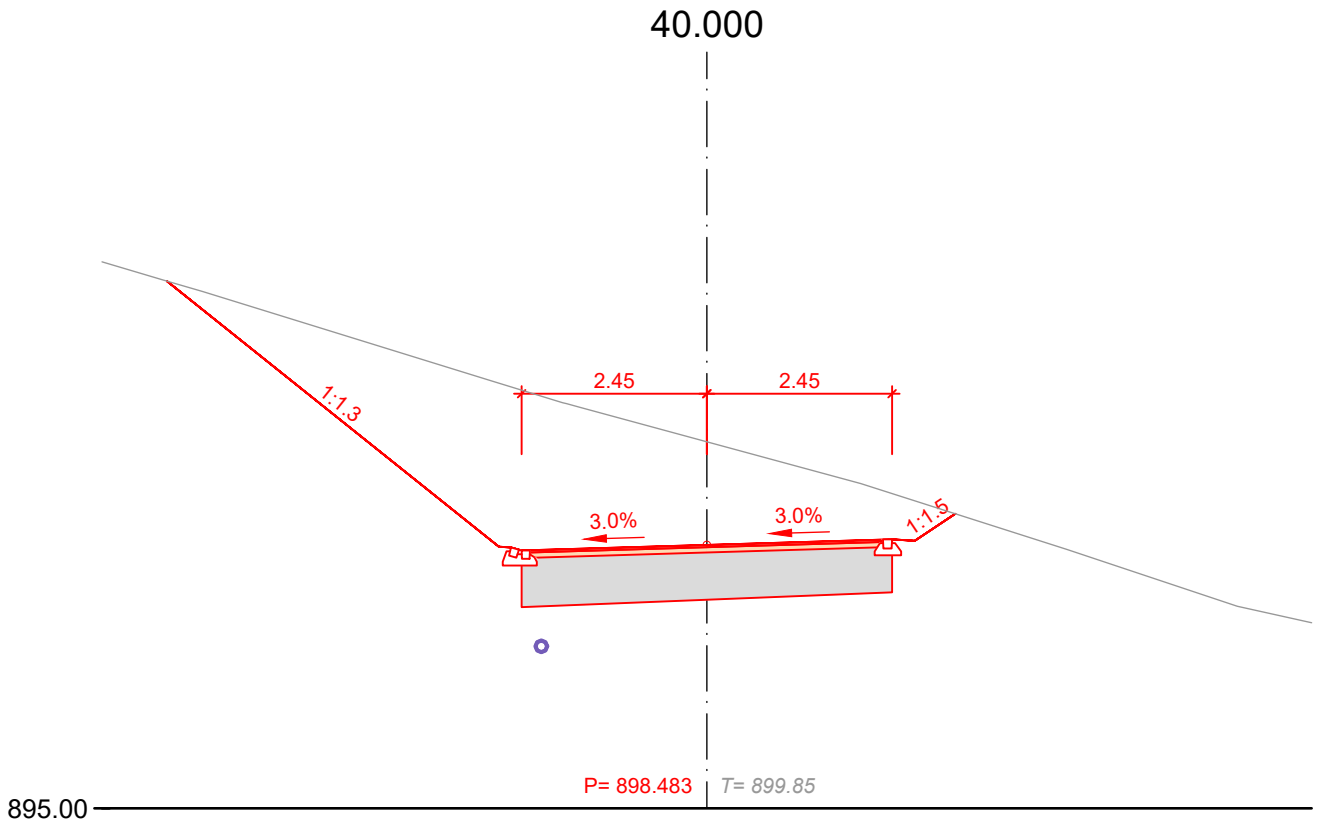

51.021

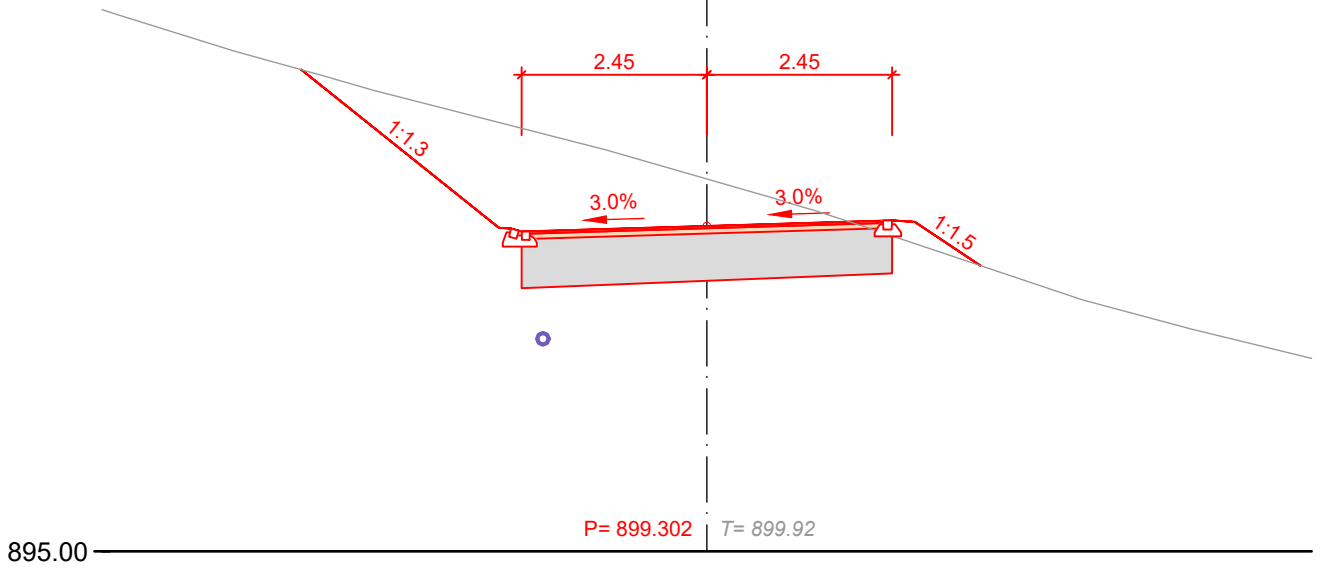

60.000

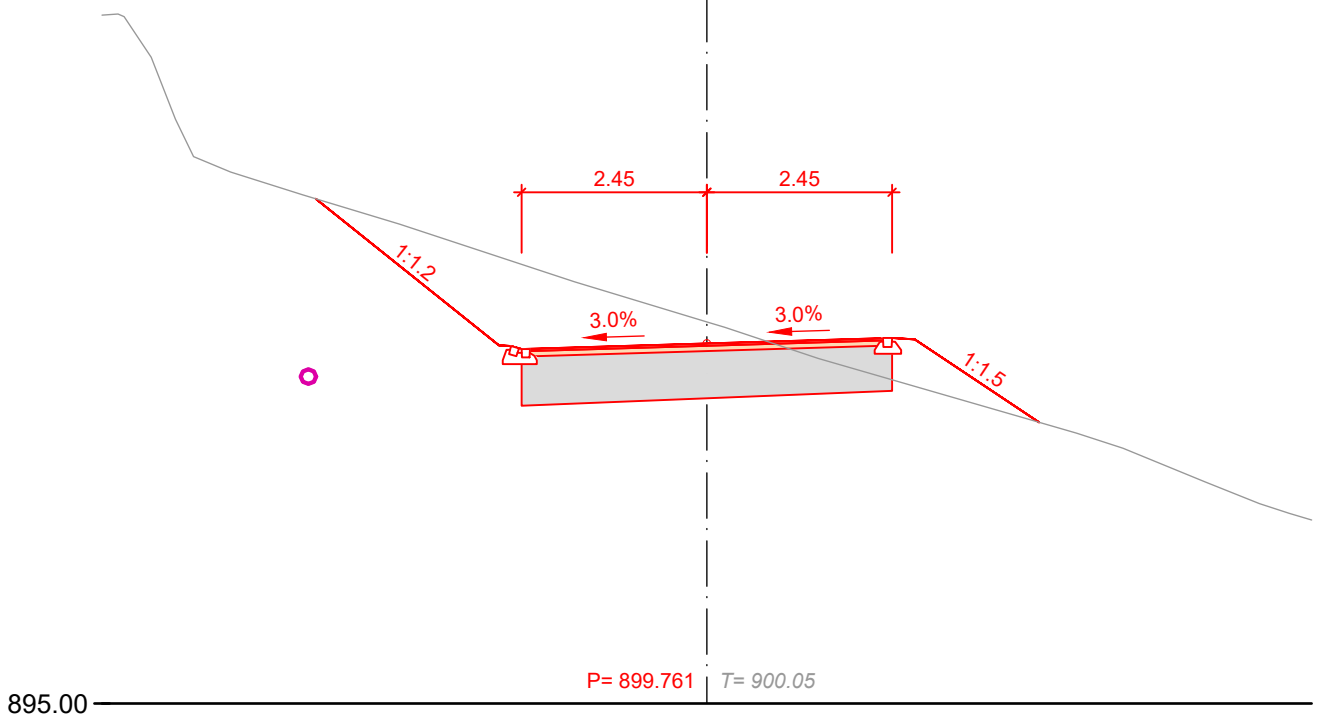

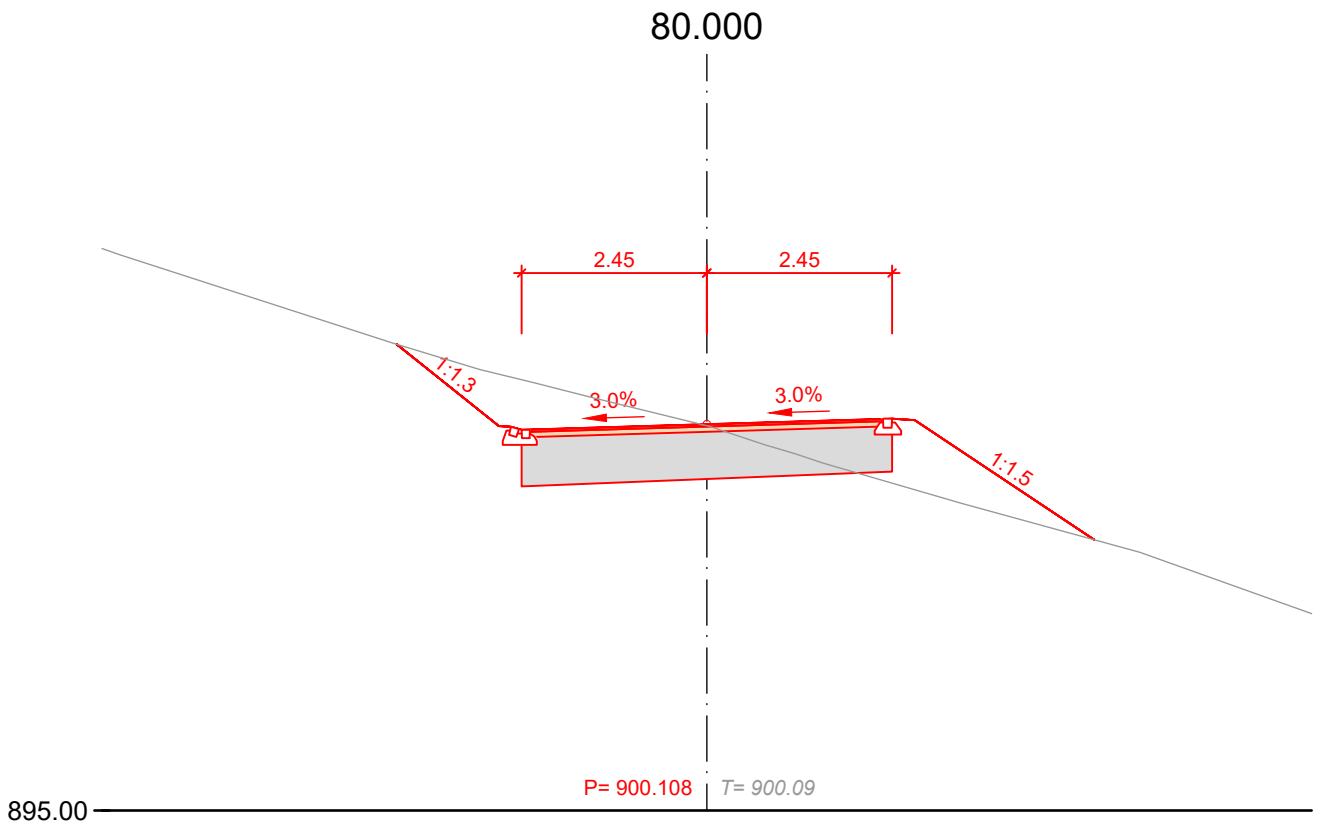
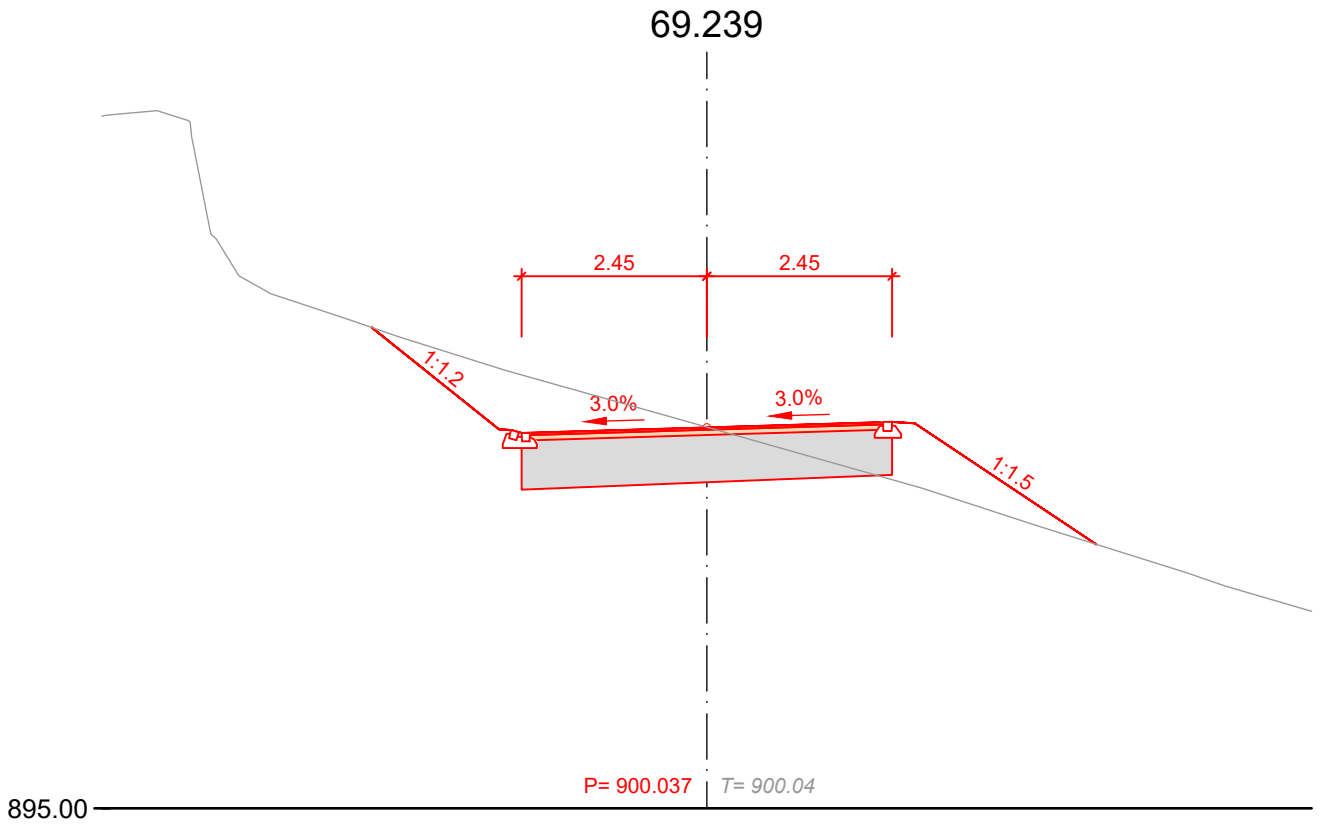

128.213

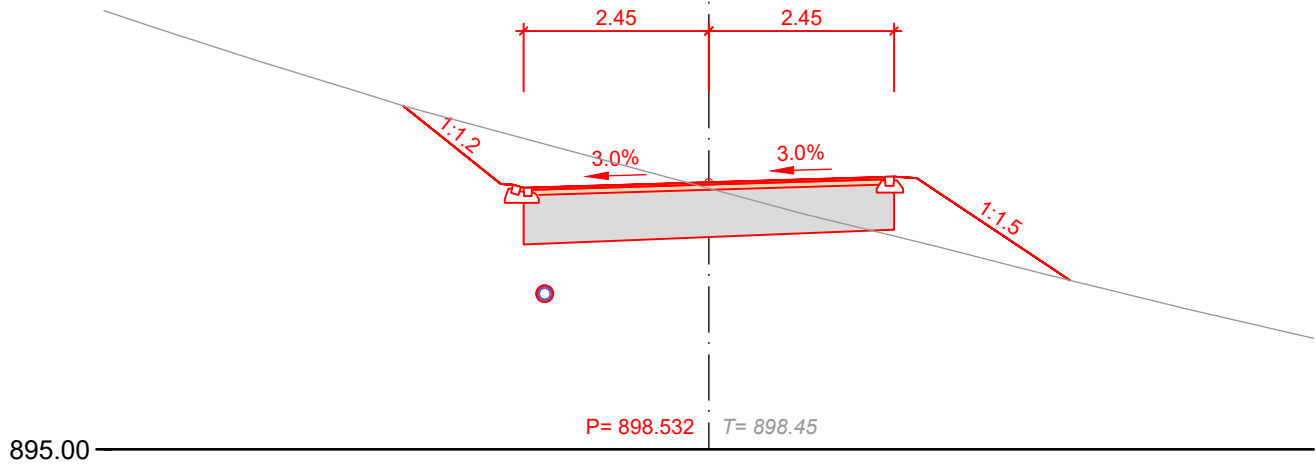

136.641

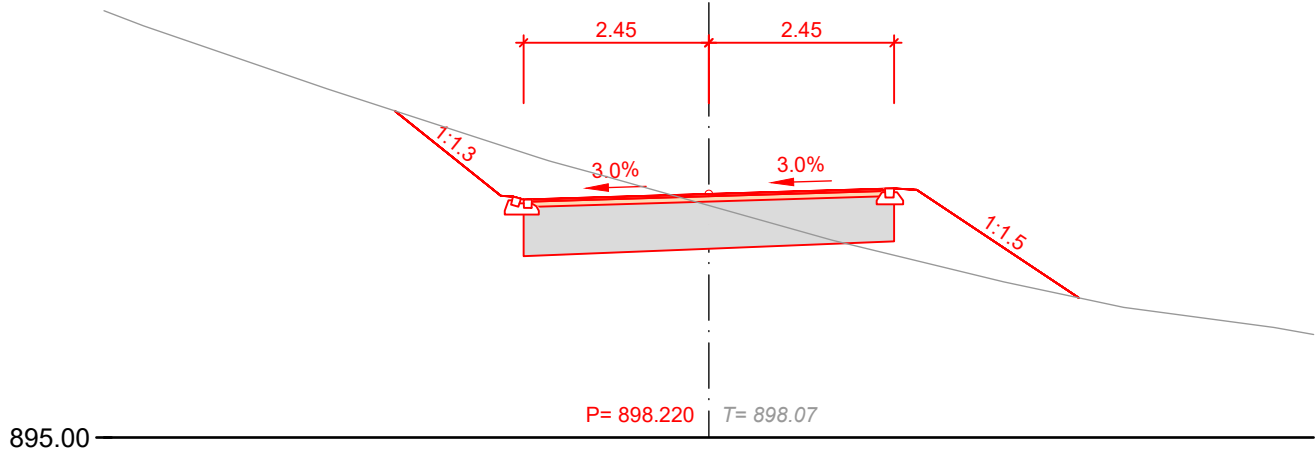

145.068

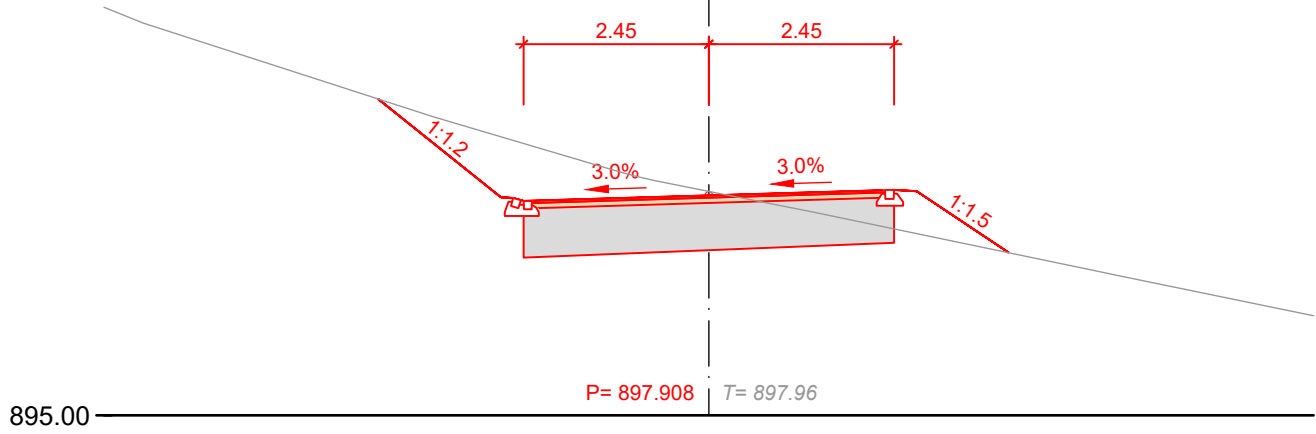

150.000

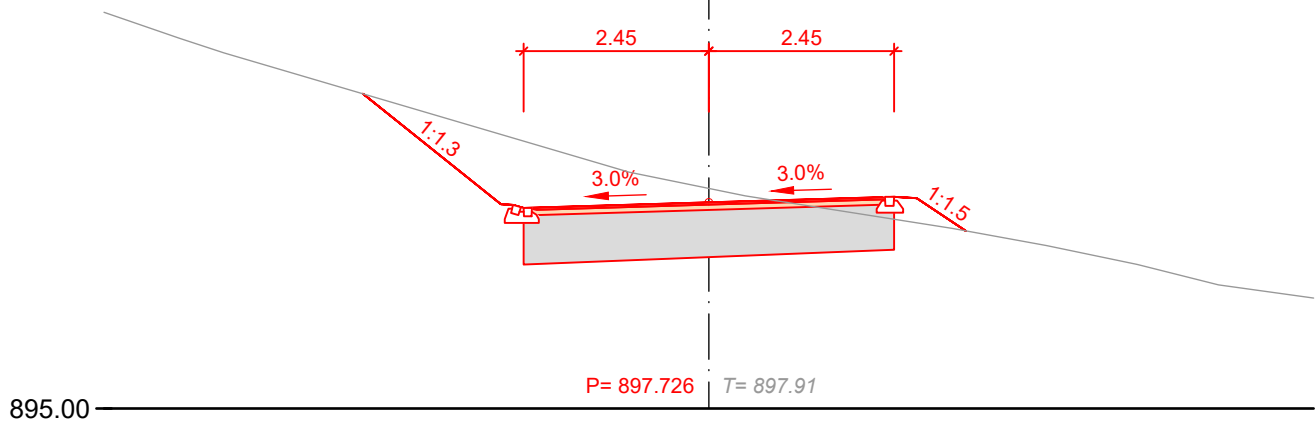

160.000

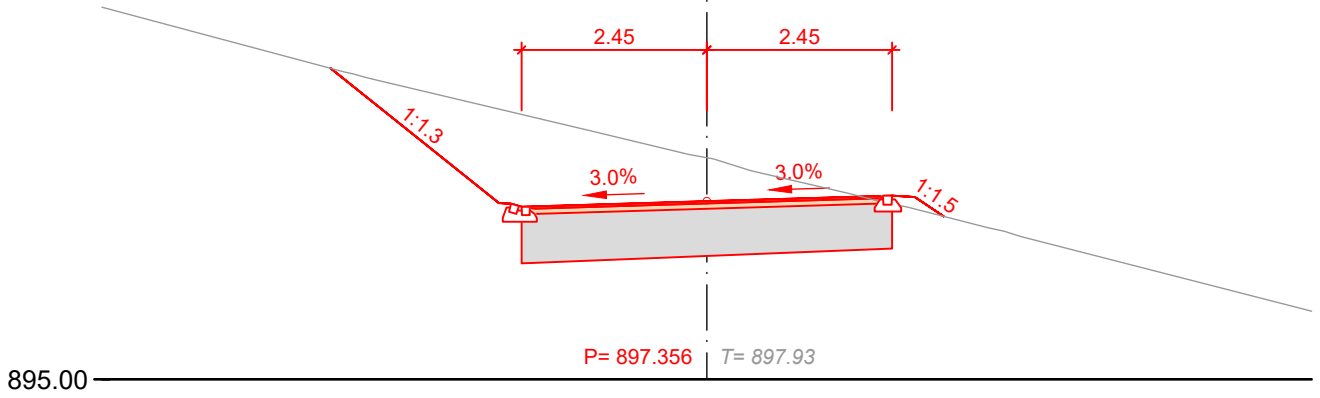

164.455

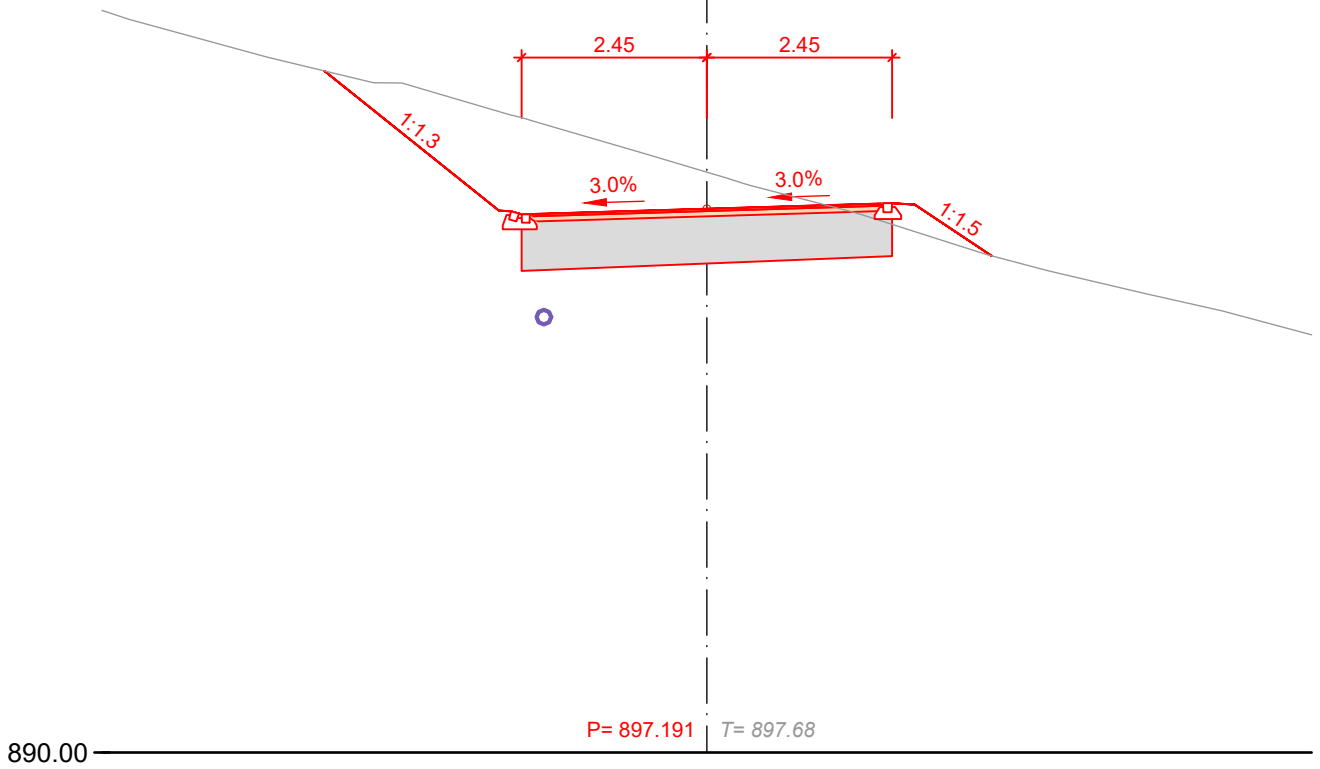

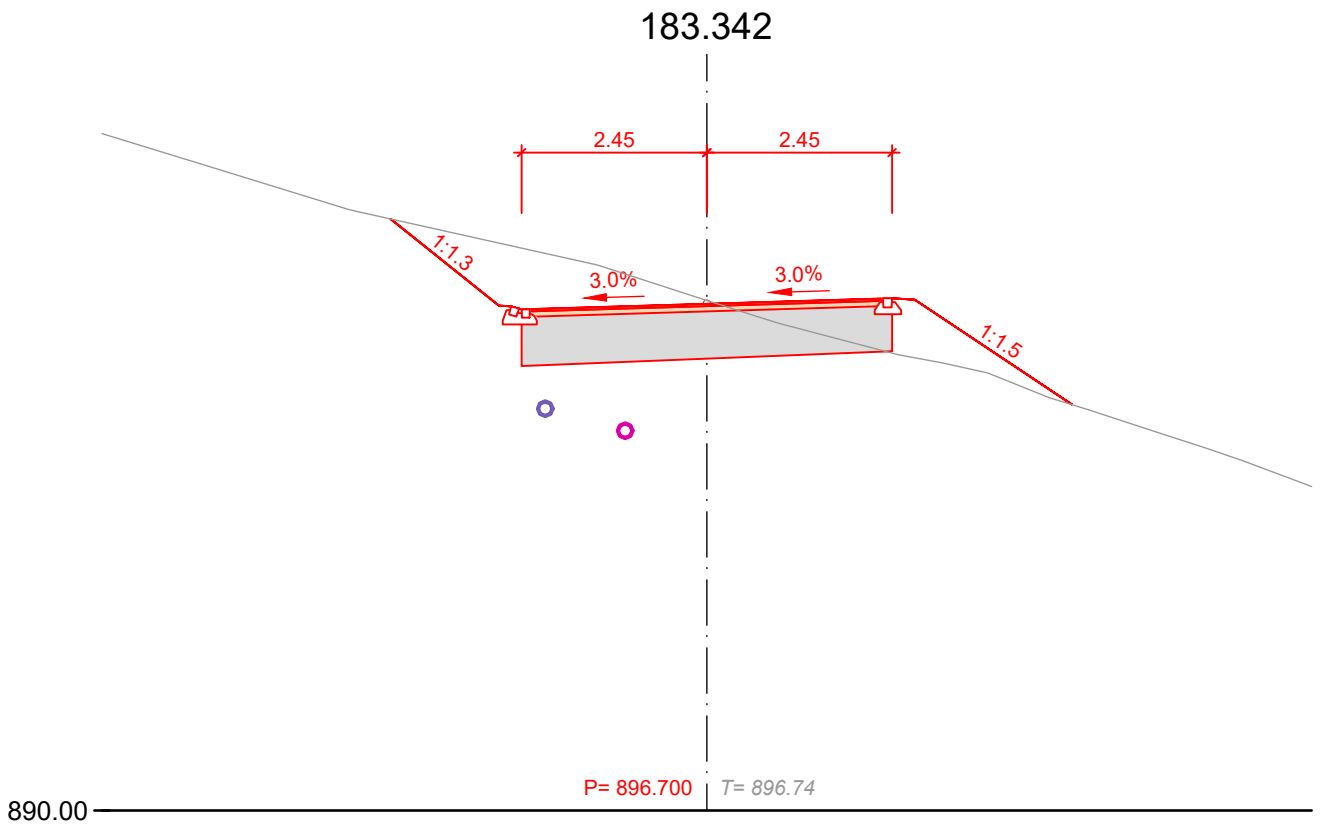
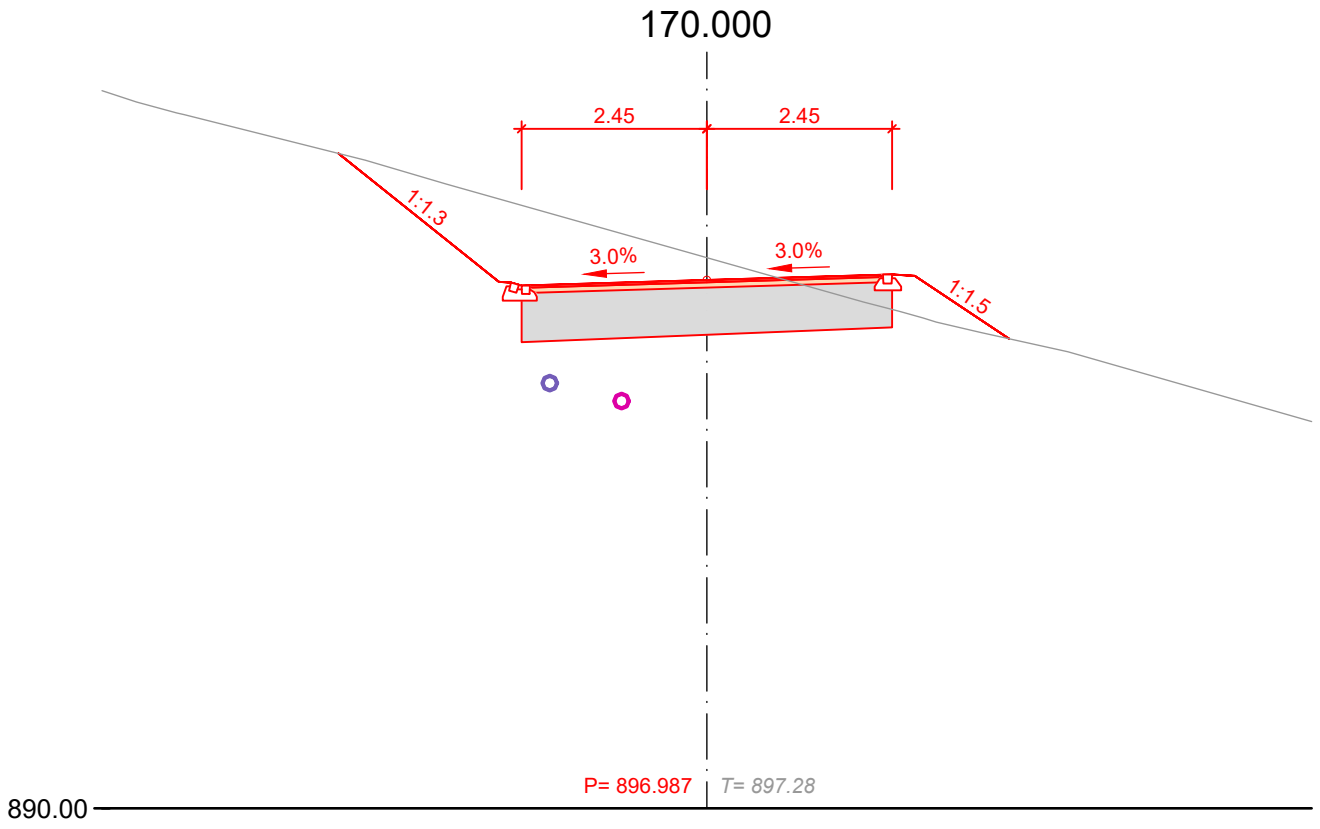

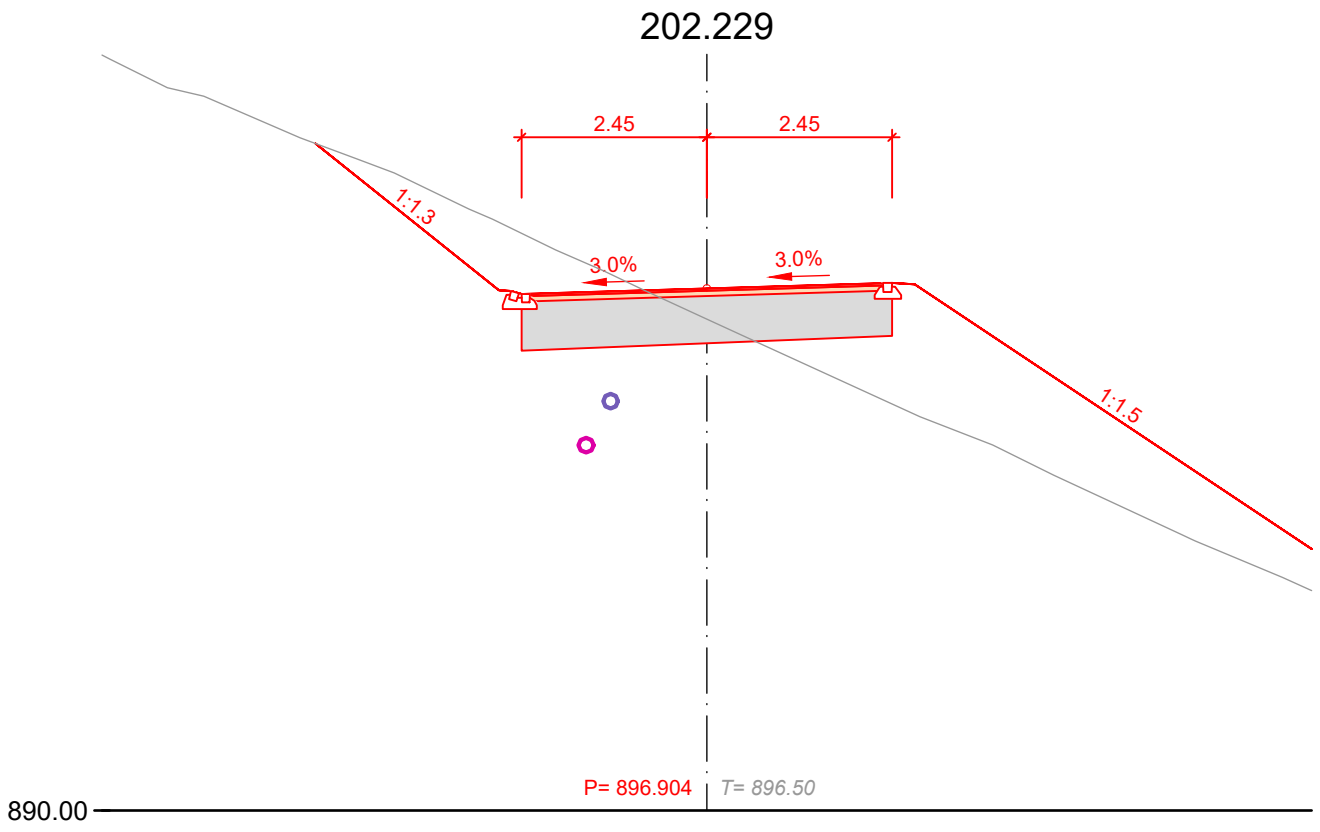
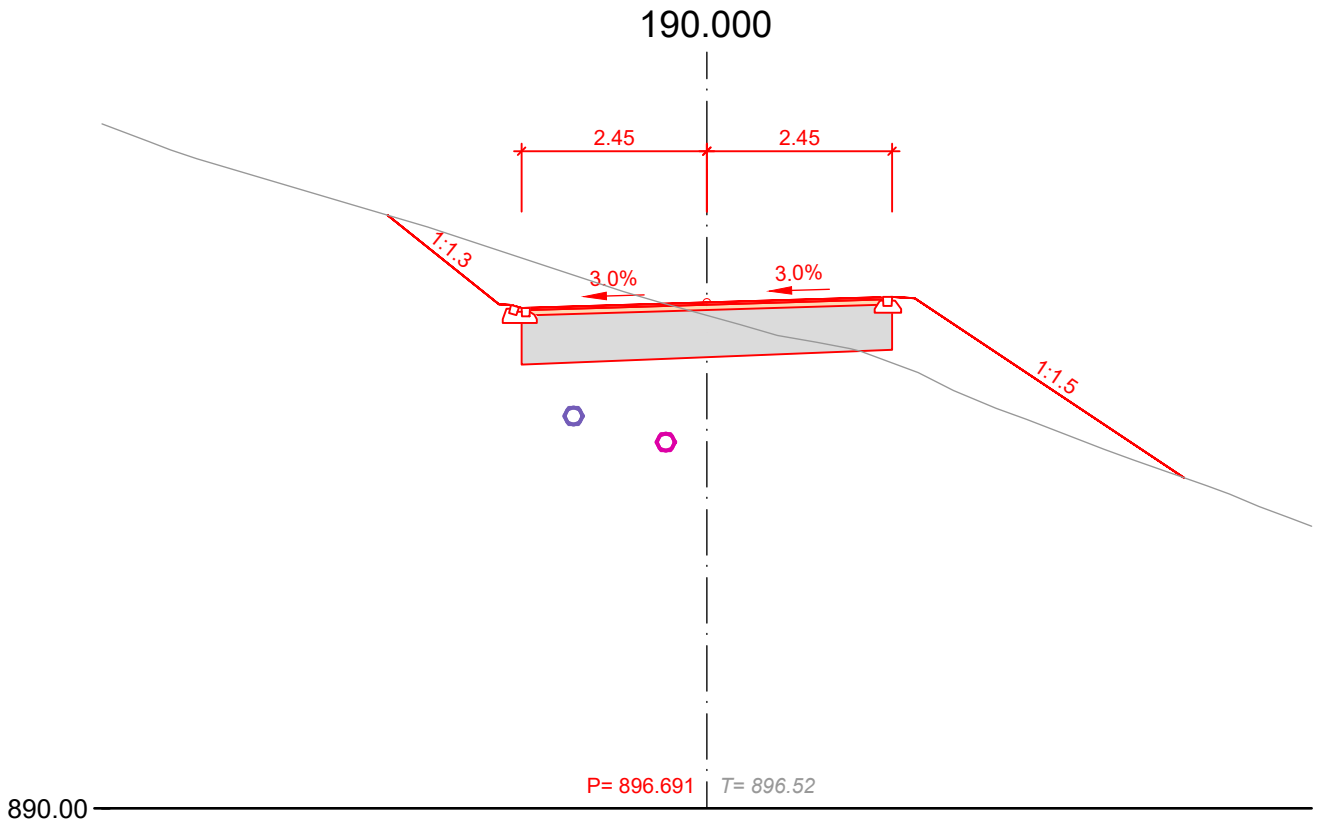

210.000

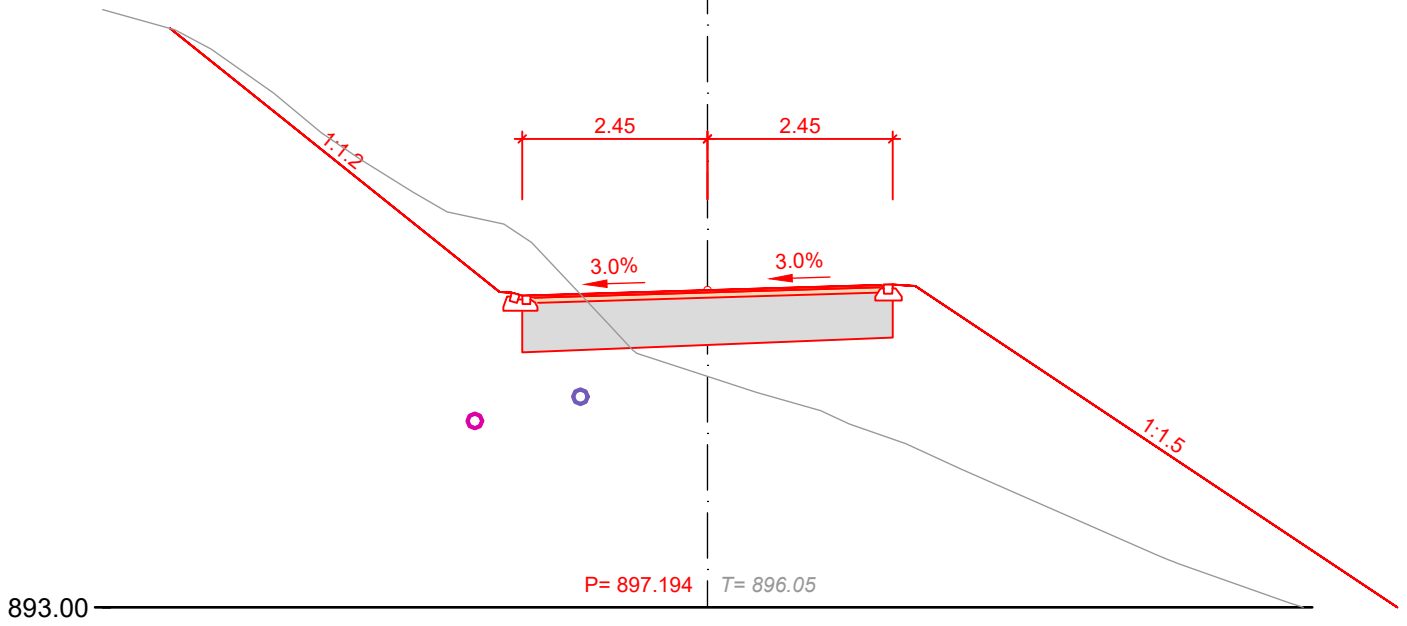

221.709

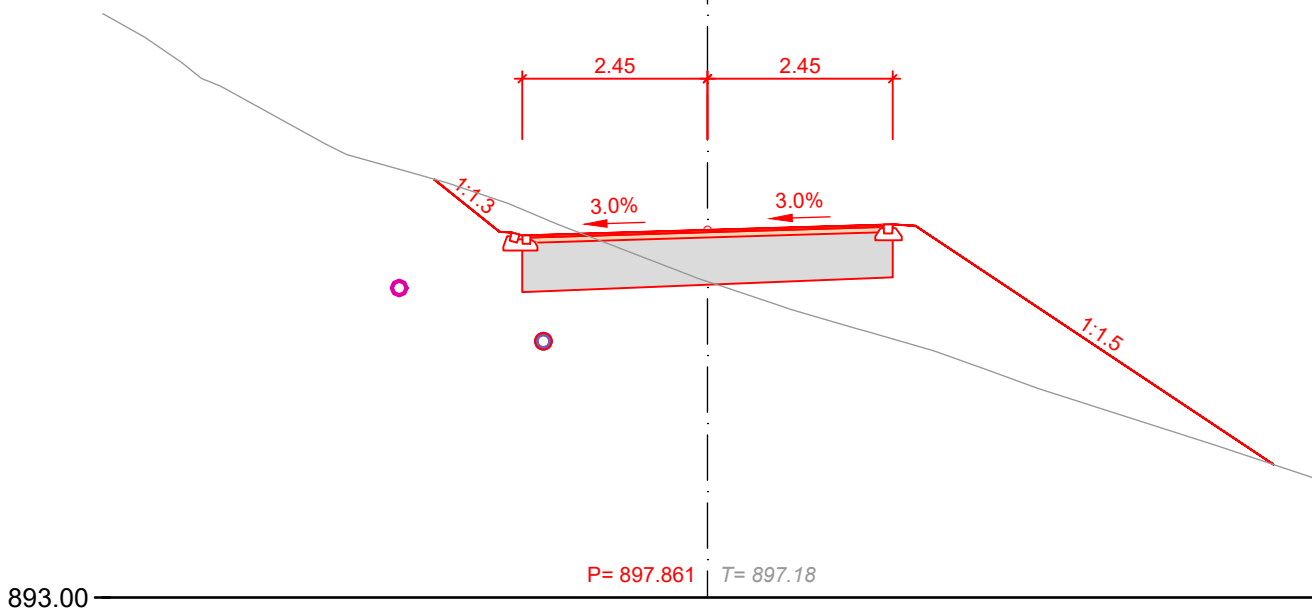

230.000

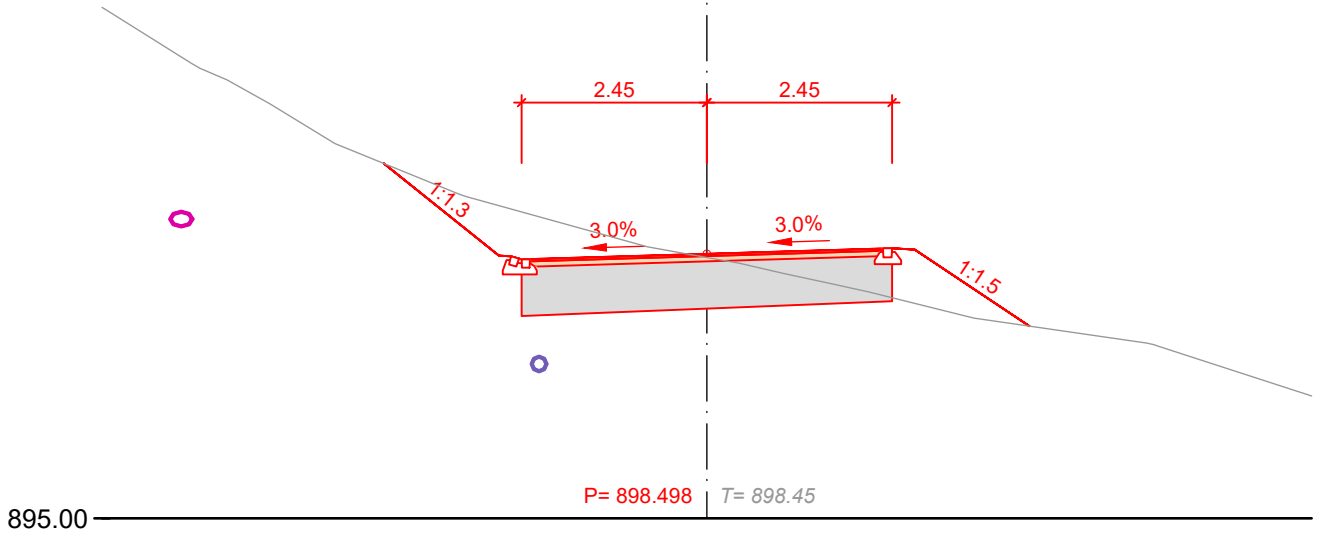

240.000

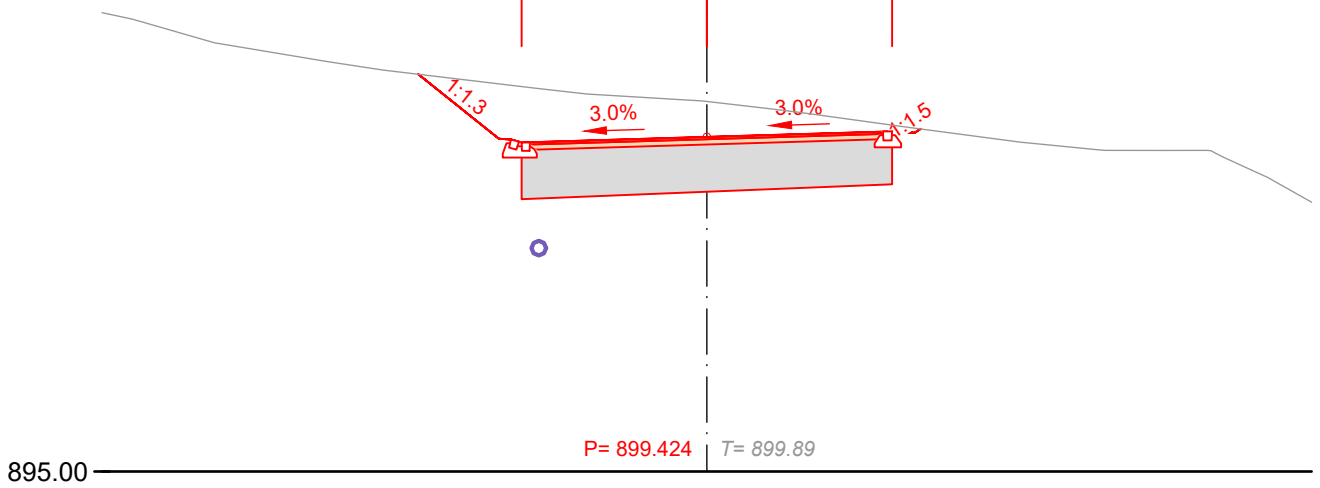

244.951

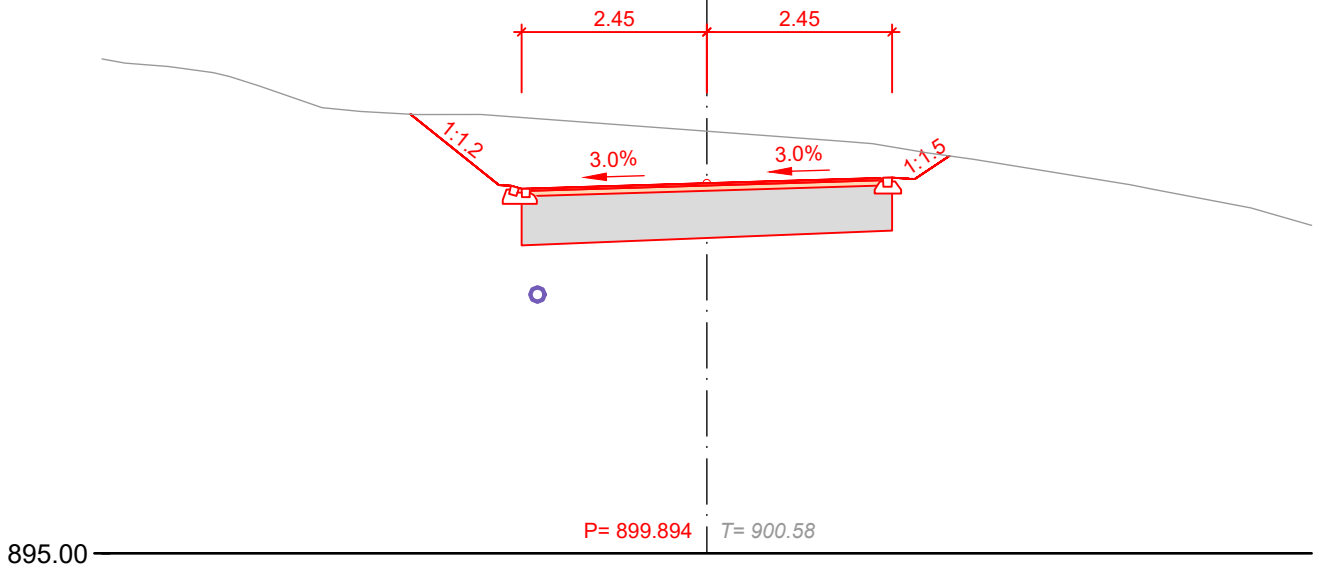

250.000

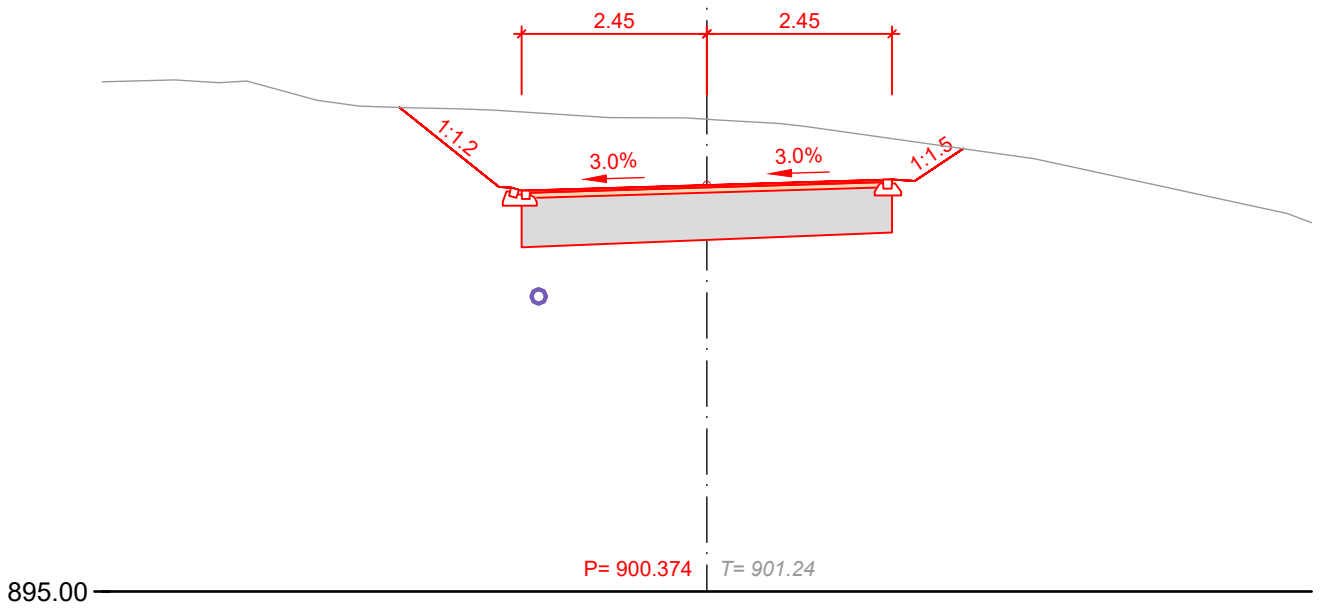

260.000

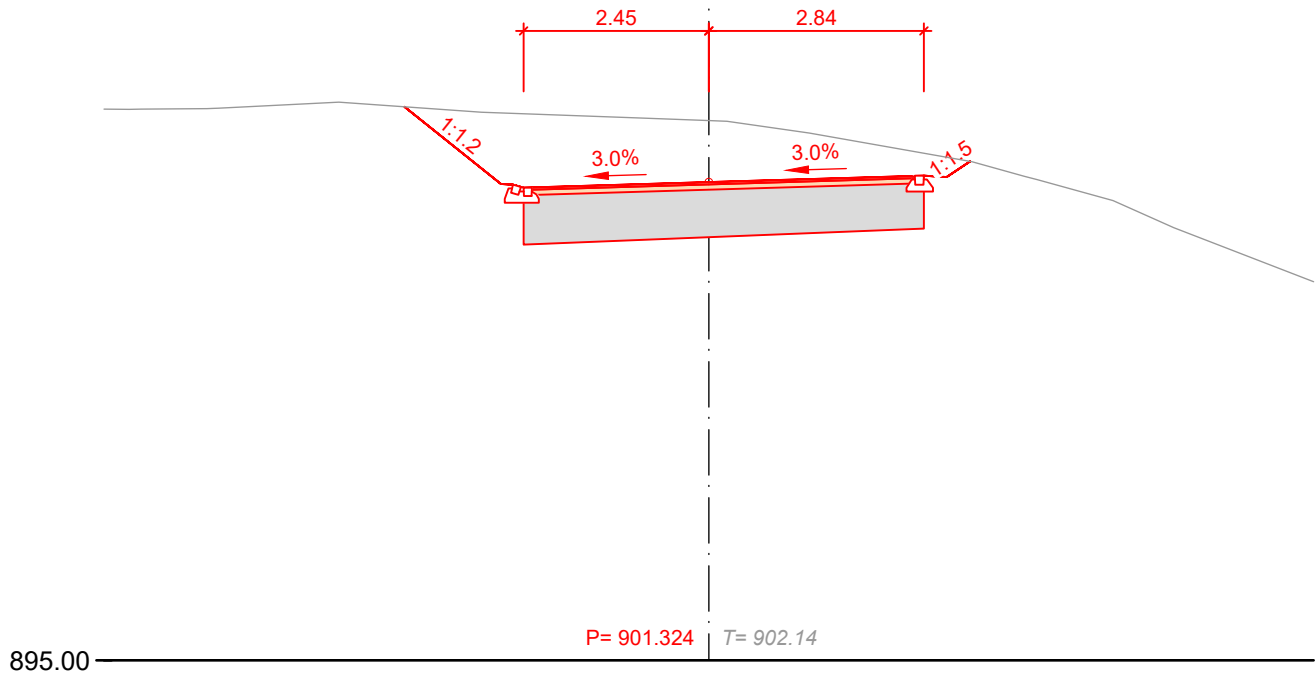

268.193

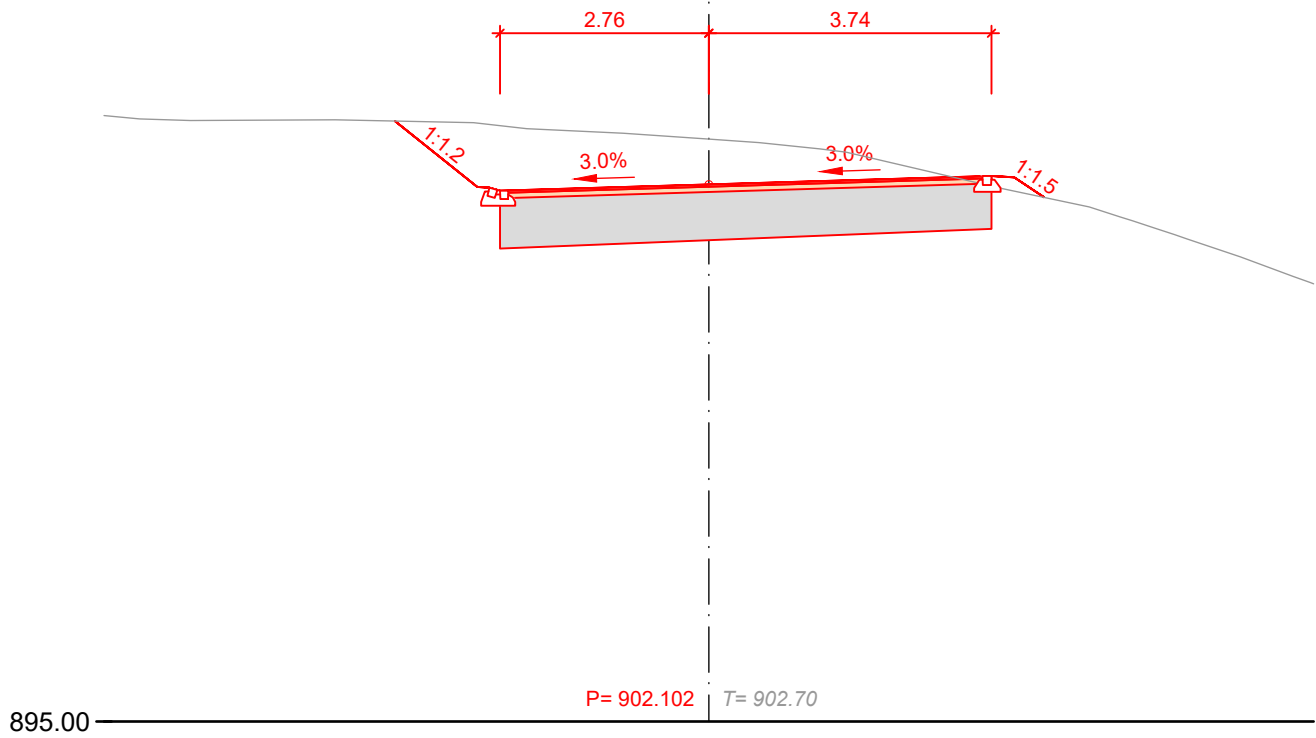

280.000

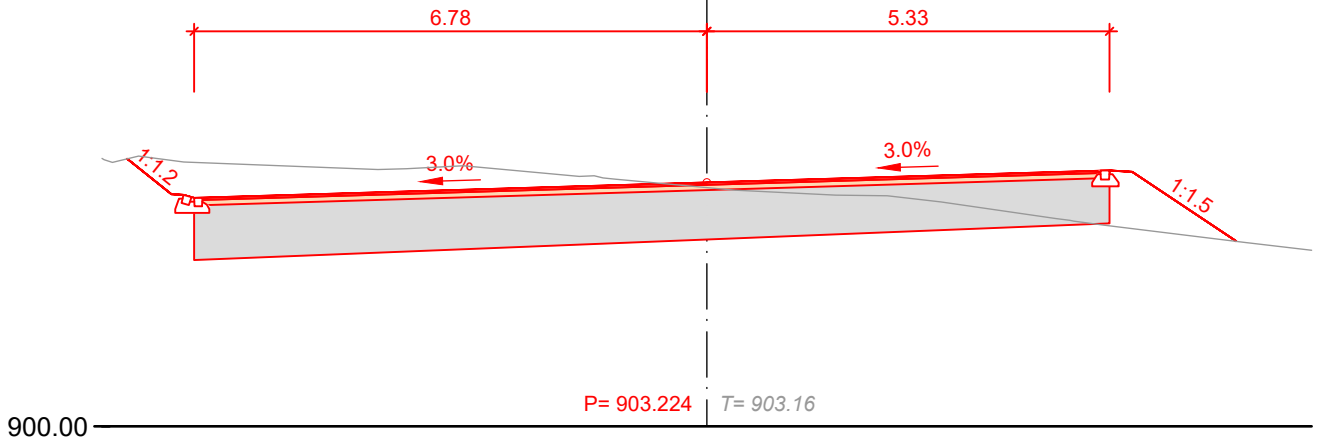

282.314

